Value-added chain and vertical integration versus outsourcing in ground handling

Xuan Hoa Bui

University of Applied Sciences Bremen

GARS Workshop Amsterdam 07/2008

Main questions

- What are the pros and cons of vertical integration and outsourcing? What would justify a vertical integration?
- Which factors determine whether an airport firm chooses vertical integration or outsourcing?
- What is the vertical size of airports in France, Germany, UK and the Netherlands? What is the usual organizational form?

Overview

- The aviation industry
- Vertical integration versus outsourcing
 - Transaction cost theory
 - Outsourcing: pros and cons
 - Determining an airport's vertical size
- Vertical size of airports in UK, France, Germany and the Netherlands
- Vertical integration or outsourcing?
- Conclusion

The aviation industry

- Liberalization of the European air transport market
- Fierce competition driven by price pressure and new trends in the industry
- Huge potential for developing competitive advantages in ground handling

The aviation industry

Ground handling

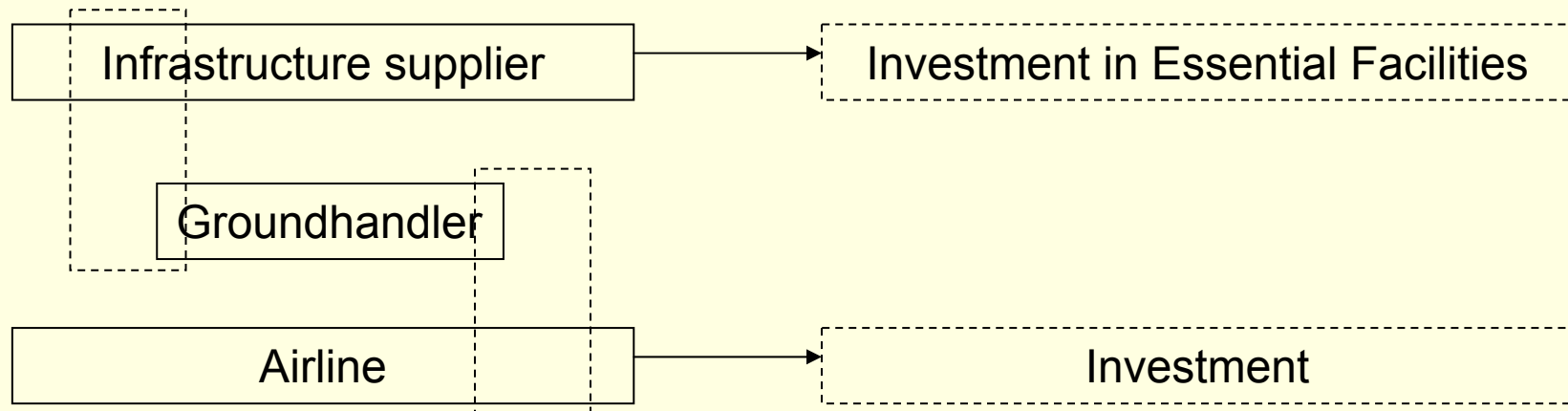

Transaction delivery of handling services

Vertical integration versus outsourcing

- Transaction costs:
 - costs related with negotiating, creating and enforcing an exchange relation
 - opportunity costs associated with adjustments needed to address unsatisfactory performance upon ex-post revelation

Vertical integration versus outsourcing

Relationship-specific assets

- Site specificity
- Physical asset specificity
- Dedicated asset specificity
- Human asset specificity
 - ➔ Large number bargaining or small number bargaining depending on the level of asset specificity

Vertical integration versus outsourcing

Hold-up problem

- Prevalence of incomplete contracts in reality
- Direct correlation between the level of asset specificity and the amount of quasi-rents

 Attempt of one party to take advantage of an incomplete contract to get one portion of the other party's quasi-rents

Vertical integration versus outsourcing

Uncertainty

Infeasibility of a complete contract due to

- Bounded rationality
 - Difficulty of measuring effort and service quality of handlers
 - Asymmetric information
-  Correlation between the size of airport and level of uncertainty

Vertical integration versus outsourcing

Outsourcing

Advantages

- Tangible benefits:
exploitation of specialized know-how, scale economies of market firms, focus on core activities
- Intangible benefits:
avoidance of agency and influence costs

Disadvantages

- Coordination difficulty
- Leakage of private information

Vertical integration versus outsourcing

Trade-off between agency and technical efficiency

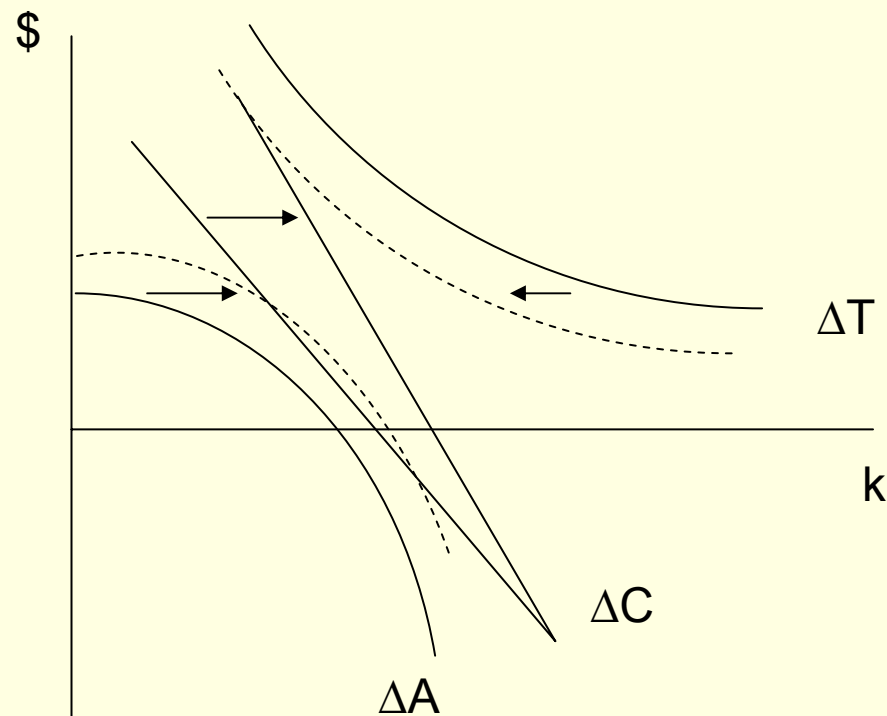

ΔA : transaction costs under vertical integration minus transaction costs under outsourcing

ΔT : minimum production costs under vertical integration minus minimum production costs under outsourcing

ΔC : total cost difference, sum of ΔA and ΔT

Vertical integration versus outsourcing

Determining an airport's vertical size

- Trade-off between technical and agency efficiency dictated by product market scale, economies of scale and scope, level of asset specificity
- Influence of asset ownership

Vertical size of airports in UK, France, Germany and the Netherlands

Scale of each airport's centralised infrastructure

Market	Baggage Assisting facilities	De-icing facilities	Passenger bridges	400 Hz-Facilities, fix	Refuelling equipment	Toilet facilities	Check-in counter
LHR	not defined						
CDG	x	x			x	x	
FRA	x	x	x	x	x	x	x
AMS	not defined						

Vertical size of airports in UK, France, Germany and the Netherlands

Outsourcing level at four hub airports

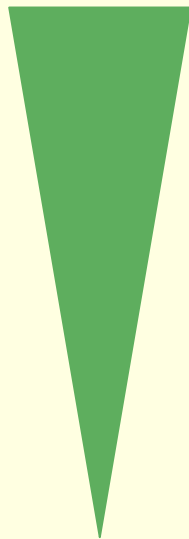

CDG: Extensive usage of centralised infrastructure for ground handling

LHR: Partial usage of centralised infrastructure for ground handling

AMS: Little usage of centralised infrastructure for ground handling

FRA: Usage of centralised infrastructure only for internal cleansing

Vertical size of airports in UK, France, Germany and the Netherlands

Selection of ground handlers at each airport terminal

Market	Terminal	Airport operator	Airlines	Independent ground handler	Total number of ground handler
LHR	1		3	3	6
	2		2	2	4
	3		2	2	5
	4		1	1	2
CDG	1	1	1	1	3
	2	1	1	1	3
	3	1	1		2
FRA	1, 2	1		1	2
AMS	1, 2, 3		1	3	4

Vertical integration or outsourcing?

- Effects of the market deregulation:
 - Decreasing price
 - Ambiguous effect on quality (counterbalance between price pressure and specialized know-how of independent handlers)
 - Capacity issues
 - Increasing job insecurity, declining work conditions
- Negative effect of EU competition rules on the possibility of vertical integration
- Vertical integration of airports: a rarity in Europe

Conclusion

- Heterogeneity in vertical size of airports across Europe
- Need to consider the market scale and extent of scale and scope economies as well as level of asset specificity
- Complex decision over an airport's vertical size, no standard solution

Next steps

- Research of vertical size of airport firms in other fields, i.e retailing or airline-airport relationships
- Applicance of Principal-Agent Theory and/or a deeper analysis of Transaction Cost Theory
- Observation of airports in other European countries



Thank you for your attention!